

BARITONE T.C.

W26TC

STANDARD OF EXCELLENCE

# FIRST PERFORMANCE

*13 Pieces in a Variety of Styles for Beginning Band*

BY BRUCE PEARSON & BARRIE GOTT

**PNBHS MUSIC DEPT**

**STACK COPY**

**Do not remove from  
Department**

re cor  
to the school  
**FIRST PERFORMANCE**  
On Friday, 8 p.m.  
DAG O' BLUES

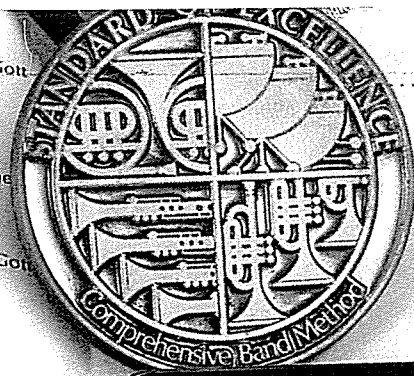

LEWIS EADY LTD  
09 524 4119  
W26TC AA  
\$17.50 inc GST

FIRST PERFORMANCE  
BARITONE T.C./MUSICO



# TABLE OF CONTENTS

A CHILDREN'S CHRISTMAS CAROL <i>"O Come, Little Children"</i> .....	2
THE FRIENDLY BEASTS .....	3
RIO BRAVO .....	4
BIG ROCK CANDY MOUNTAIN .....	5
ROYAL CROWN MARCH .....	6
BOOT SCOOTIN' BARN DANCE .....	7
BAG O' BLUES .....	8
A LITTLE BIT OF LATIN .....	9
A CLASSICAL CANON .....	10
DR. ROCK .....	11
FANFARE AND MINUET FROM "THE ROYAL FIREWORKS MUSIC" .....	12
BOOGIE BLUES .....	13
MINOR ROCK .....	14
GLOSSARY .....	15

BARITONE T.C.

STANDARD OF EXCELLENCE

# FIRST PERFORMANCE

*13 Pieces in a Variety of Styles for Beginning Band*

BY BRUCE PEARSON & BARRIE GOTT

Dear Student:

Welcome to the STANDARD OF EXCELLENCE FIRST PERFORMANCE, a collection of thirteen songs written for beginning or young band. These selections represent a variety of musical styles such as rock, blues, marches, traditional folk songs, and transcriptions from classical music.

Each piece was composed or arranged especially for the first year band student and contains a limited range of musical notes as well as simple rhythms designed to provide beginning instrumentalists a repertoire of varied fun and exciting concert music.

Good luck with your First Performance!

Best wishes,



Bruce Pearson



Barrie Gott

ISBN 0-8497-0662-9

©2001 Neil A. Kjos Music Company, 4380 Jutland Drive, San Diego, California, 92117.  
International copyright secured. All rights reserved. Printed in the U. S. A.

**Warning!** The contents of this publication are protected by copyright law. To copy or reproduce them by any method is an infringement of the copyright law. Anyone who reproduces copyrighted matter is subject to substantial penalties and assessments for each infringement.

 NEIL A. KJOS MUSIC COMPANY • PUBLISHER

W26TC

# A CHILDREN'S CHRISTMAS CAROL

## "O COME, LITTLE CHILDREN"

Baritone

J.A.P. Schulz/Magill

1 **Moderato** 2 3 4 5 6

7 8 9 10 11 12

13 14 15 16 17 18

19 20 21 22 23 24

25 26 27 28 29 30

31 32 33 34 35 36

37 38 39 40 41 42 43

**O Come, Little Children** was composed by Johann Abraham Peter Schulz (b.1747 - d.1800). Schulz was the court composer at Rheinsberg, Germany and a choir director for the Royal Court Theater in Copenhagen, Denmark. He was best known for setting poems to simple, folk-like music. The German poet, Christoph von Schmid, wrote the words to this song.

# THE FRIENDLY BEASTS

Baritone

Medieval French Melody

1 **Andante** *mp* 2 3 4 5

6 7 8 9 10

11 12 13 14 15 16

17 18 19 20 21 22 *mf* *mp*

23 24 25 26 27 28

29 30 31 32 33 34

35 36 37 38 39 *f*

40 41 42 43 44 *p*

The melody for **The Friendly Beasts** dates back to 12th century medieval France while the words were written at a later date. **The Friendly Beasts** is usually thought of as an old English carol.

## Baritone

## RIO BRAVO

1-8 Allegro moderato 9

8 9 10 11 12 13

*mf*

14 15 16 17 18 19

20 21 22 23 24 25

*f*

26 27 28 29 30 31

*mf*

32 33 34 35 36 37

38 39 40 41 42 43

44 45 46 47 48 49

*mf*

50 51 52 53 54 55 56

*f*

Latin America is made up of South America, Central America, Mexico, and the West Indies. The music of this region is a combination of Spanish, Portuguese, and Italian traditions and has been influenced by the cultures of the native Indians like the Aztec, Incan, and Mayan. It features catchy melodies, infectious rhythms, and a wide use of percussion instruments.

# BIG ROCK CANDY MOUNTAIN

Baritone

Traditional American Folk

1-2 **Allegro** 2

*mf*

3 4 5 6 7

8 9 10 11 12 13

14 15 16 17 18 19

20 21 22 23 24 25

*f*

26 27 28 29 30 31

32 33 34 35 36 37-38 2 39 40

*ff*

Folk songs are passed down from generation to generation through singing and listening. The common folk sing the songs to their children instead of writing them down. The original composers were forgotten as time passed and the words and places changed. These changes left many versions of the same song. **Big Rock Candy Mountain** originated in the late 1800's and was attributed to Harry "Haywire Mac" McClintock. The ballad tells of a hobo's life, riding the trains and traveling the country, in search of the perfect place for a "burly bum" to live.

# Boritone ROYAL CROWN MARCH

1 Moderato

The musical score is written for a Boritone instrument in 4/4 time, marked Moderato. It consists of 64 measures across nine staves. The dynamics are marked as follows: *f* (measures 1-4), *mf* (measures 5-12), *p* (measures 21-24), *mf* (measures 29-30), *f* (measures 38-44), *mf* (measures 45-50), and *f* (measures 61-64). Measure numbers 1, 2, 3, 4, 5, 6, 7, 8, 9, 9, 10, 11, 12, 9, 13, 14, 15, 16, 9, 17, 18, 19, 20, 21, 22, 23, 24, 9, 25, 26, 27, 28, 29, 30, 31, 32, 9, 33, 34, 35, 36, 37, 38, 39, 40, 41, 42, 43, 44, 45, 46, 47, 48, 9, 49, 50, 51, 52, 9, 53, 54, 55, 56, 9, 57, 58, 59, 60, 61, 62, 63, 64 are indicated above the notes. The score begins with a treble clef and a 4/4 time signature. The music features a steady, accented beat characteristic of a march.

The history of the march has its beginnings in the military. Marches have a steady beat that is strongly accented. This beat was helpful for soldiers to stay in step. Many marches were written to commemorate a regal occasion such as the crowning of a king. It was with this in mind that **Royal Crown March** was composed.



# BOOT SCOOTIN' BARN DANCE

Baritone

Ron Cowherd  
Traditional American Folk

1 Allegro

2 3 4 Tap foot 5 mf 6 7

8 9 10 11 12 13 14

15 16 17 18 19 20 21 Tap foot

22 Clap hands 23-24 2 25 26 27 28 29

30 31 32 33 34 35 36

37 38 39 40 41 42 43-44 2

45 mf 46 47 48 49 50 51

52 53 54 55 56 57 58 59 60

61 62 63-64 2 Clap hands Slap knee Tap foot 68 Hey!

A significant part of a country's heritage and culture is found in its folk music. Using the language of the common folk, folk songs describe the lives and times of its people. This piece uses the folk song, **Ol' Joe Clark**. Joe Clark was a veteran from the war of 1812 who lived in the Appalachian Mountains. The numerous verses were made up from incidents in his life and expanded as time passed to include over 90 different verses.

# BAG O' BLUES

Baritone

Moderato  $\frac{4}{4}$

*mf*

*f*

The blues is a style of music developed from the African-American field hollers, work songs, and spirituals of the late 1800's to early 1900's. It is played at a slow to moderate tempo and usually written in 4/4 time. The third, fifth, and seventh notes of the scale in which the piece is written are lowered one half-step.

# A LITTLE BIT OF LATIN

Baritone

1 Moderato

mp

13

19

mf

25

mp

31

f

37

43

mp

50

mp

The music of Latin America, influenced by the many cultures and traditions of its people, uses lively rhythms for dances like the habanera, rumba, cha-cha, and tango. The music uses many percussion instruments such as the claves, maracas, and cowbell to keep the rhythm.

# A CLASSICAL CANON

Baritone

Franz Joseph Haydn/Magill

1-4 **Andante** 4 5 6 7 8 9

*mp*

10 11 12 , 13 14 15

*mf*

16 17 18 19 20 21-22 **2**

23 24 25 26 27 28

*mf*

29 30 , 31 32 33 34 9

*f*

35 36 37 38 39 40 41 42

Franz Joseph Haydn (b.1732 - d.1809) was an Austrian composer who worked as the court composer for the royal Esterhazy family for over thirty years. "Papa Haydn," best known for his numerous symphonies and string quartets, also trained and conducted the other court musicians. **A Classical Canon** was originally called the *Nightingale Canon*. Words were added later describing children's anticipation to stay up on Christmas Eve while the parent sang for the children to go to bed. The title then became commonly known as the *Christmas Eve Canon*.

# DR. ROCK

Baritone T.C.

Chuck Elledge

1 *Allegro moderato* 2 3 4 5

6 7 8 9 10 11

12 13 14 15 16 17

18 19 20 21 22 23

24 25 26 27 28 29 30

31 32 33 34 35 36

37 38 39 40 41 42

43 44 45 46 47 48 49

50 51 52 53 54 55

Rock music evolved into a distinctive style of music with songs like *Rock Around the Clock* and *You Ain't Nothin' But a Hound Dog*. During the 1960's, a British band called the Beatles became very popular. In the 1970's and 1980's, electronic instruments and advanced recording techniques were developed to enhance the music.

# FANFARE AND MINUET FROM "THE ROYAL FIREWORKS"

Bariitone

George Frideric Handel

1 **Moderato**

2 3 4 5 6

7 8 9 10 11 12

13 14 15 16 17 18 19

20 21 22 23 24 25 26

27 28 29 30 31 32 33

34 35 36 37 38 39 40

41 42 43 44 45 46

47 48 49 50 51 52

*f*

*mf*

*ff*

George Frideric Handel (b.1685 - d.1759) was a popular German composer who traveled widely throughout his life and settled in England. The English royalty paid him well for his many compositions. The **Music for the Royal Fireworks**, written in 1749, originally called for a huge ensemble of brass, woodwinds, timpani, and a cannon. Handel wrote the piece to accompany a fireworks celebration for the King of England. Just as the music began, the fireworks exploded accidentally. In spite of the accident, Handel's piece was a great success.

Baritone

# BOOGIE BLUES

1 **Allegro moderato**  $\text{♩} = \text{♩}^{\sim 3}$

mf

6 7 8 9 10 11

12 13 14 15 16 17

f

25 **Solos (repeat as necessary)**

mf

26 27 28 29

30 31 32 33 34 35 36

Repeat as necessary

37

f

38 39 40 41

42 43 44 45 46 47

25 **Ad lib solo**

mf

26 27 28 29 30

31 32 33 34 35 36

Blues music evolved throughout the early 20th century. "Boogie-woogie," a popular style developed during this time, was normally played at a fast tempo, had a repeated melodic pattern in the bass (called a "walking bass"), swinging eighth notes, and a series of improvised variations in the upper melody.

Baritone

# MINOR ROCK

© 1993



















1 **Allegro**  
*mf*

2 3 4 5 6 7 8 9 10 11 12-13 14 15 16 17 18 19 20 21 22 23 24 25-28 29 30 31 32 33 34 35 36 37 38 39 40 41 42 43 44 45 46 47

“Rock and Roll” was a phrase used by disk jockey, Allan Freed, in the early 1950’s. He wanted to attract teenagers to his Rhythm and Blues concerts. The name caught on and rock and roll replaced American “pop” music. Rock music has a heavy dance beat with strong accents on beats 2 and 4 and lyrics that relate well to young people.



# GLOSSARY

- Accent** > ..... play the beginning of the note louder
- Accidentals** #, b, ♮ ..... sharp, flat, or natural
- Allegro** ..... quick and lively
- Andante** ..... moderately slow
- Articulation** ..... type of attack used to play a note or group of notes
- Bar Line**  ..... divides the music staff into measures
- Bass Clef**  ..... F Clef, read by bassoon, trombone, baritone, tuba, timpani, and electric bass
- Blues** ..... American genre of popular vocal music, developed from African-American field hollers, work songs, and spirituals; characterized by a harmonic structure that is made up of a 12-measure phrase
- Breath Mark** ‘ ..... take a breath
- Canon** ..... a style of contrapuntal music, similar to a round
- Carol** ..... song usually associated with Christmas
- Common Time** C ..... same as 4/4
- Crescendo** < ..... gradually play louder
- Decrescendo** > ..... gradually play softer
- Double Bar**  ..... marks the end of the music
- Dynamics** ..... loudness or softness of music
- Fermata**  ..... hold note or rest longer than its usual value
- Flat** b ..... lowers the pitch of a note by a half step
- Forte** *f* ..... loud
- Fortissimo** *ff* ..... very loud
- Harmony** ..... result of two or more different notes played or sung at the same time
- Improvise** ..... to create music as it is being performed
- Jazz** ..... style of American popular music that emerged at the turn of the 20th century and continued to evolve throughout the 20th century
- Key Signature** ..... sharps or flats stated right after the clef; key signatures change certain notes throughout a piece of music
- Ledger Lines**  ..... short lines added above or below the staff used to extend the staff to notate pitches that are beyond the range of the staff
- Long Rest**  ..... rest the number of measures indicated
- Maestoso** ..... majestically
- Measure**  ..... space between two bar lines; also known as a “bar”
- Medieval** ..... (also known as Middle Ages, 400-1400AD) a time in European history of warfare, religious devotion, and royal pageantry
- Melody** ..... organized succession of tones
- Mezzo Forte** *mf* ..... medium loud
- Mezzo Piano** *mp* ..... medium soft
- Moderato** ..... moderate speed
- Natural** ♮ ..... cancels a flat or sharp
- One-Measure Repeat**  ..... repeat the previous measure
- Percussion Clef**  ..... indicates that the lines and spaces on the staff do not designate specific pitches; also called neutral clef or no-pitch clef; read by snare drum, bass drum, cymbals, and most other auxiliary percussion instruments
- Phrase** ..... musical thought or sentence
- Piano** *p* ..... soft
- Pick-Up Note(s)**  ..... note or notes that come before the first full measure of a piece
- Popular Music** ..... music of everyday life, it has played a role in each historical period
- Repeat Sign**  ..... repeat from beginning or repeat the section of music between repeat signs
- Rhythm and Blues** ..... American style of popular music often described as an urban style of blues; instrumentation included drums, piano, electric guitar and bass, saxophone, brass, and vocalists
- Rock** ..... style of American popular music that developed in the 1960’s from rock and roll, with more amplification and distortion of sound and more room for improvisation
- Rock and Roll** ..... style of American popular music that developed from rhythm and blues in the 1950’s and was especially popular among young people
- Sharp** # ..... raises the pitch of a note 1/2 step
- Slur**  ..... curved line connecting two or more notes of different pitches
- Solo/Soli** ..... one person plays/whole section plays
- Staccato**  ..... dot placed above or below a note meaning to play short and detached
- Staff**  ..... lines and spaces on which music is written
- Swing** ..... style of American popular music that was played by the “big bands” of the 1930’s and 1940’s
- Tempo** ..... speed of music
- Tenuto**  ..... line placed above or below a note meaning to sustain for full value
- Tie**  ..... curved line that connects two notes on the same line or space
- Time Signature**  $\frac{4}{4}$   $\frac{3}{4}$   $\frac{2}{4}$  ..... top number tells the number of counts in each measure; bottom number tells the type of note that receives one count
- Treble Clef**  ..... G Clef; read by flute, oboe, clarinets, saxophones, trumpet, French horn, and mallet percussion
- Two-Measure Repeat**  ..... repeat the two previous measures

Baritone

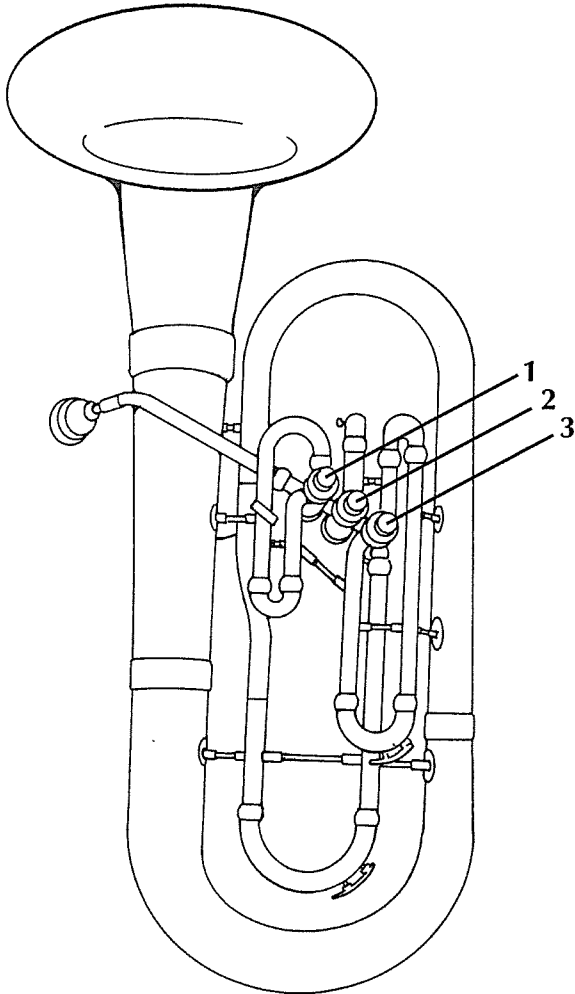

Euphonium

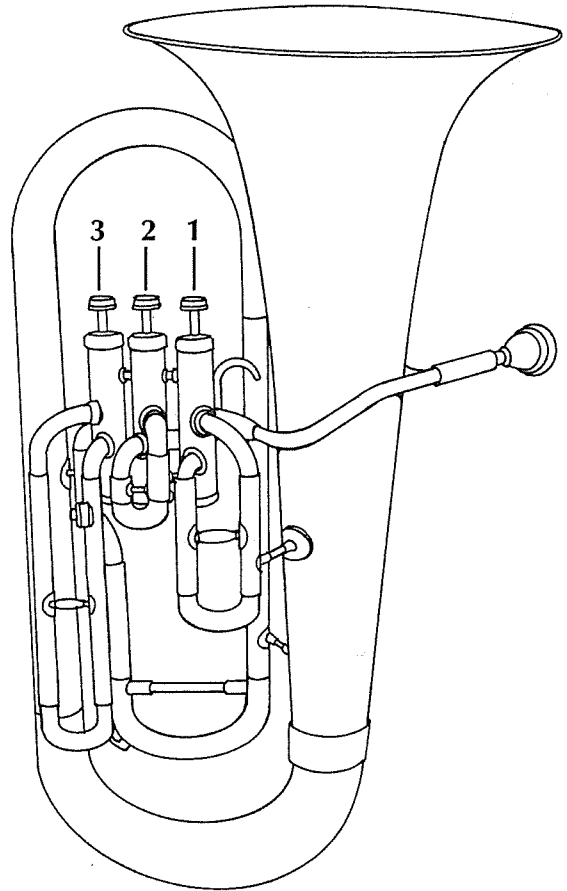

### BARITONE & EUPHONIUM CHECKLIST

- Sitting up straight
- Head erect
- Left hand and wrist position correct
- Right hand and wrist position correct
- Instrument correctly positioned in relation to body
- Fingers gently curved
- Elbows away from body
- Proper mouthpiece placement
- Corners of lips firm and center relaxed
- Chin flat and pointed
- Breathing properly
- Relaxed buzz

### BARITONE & EUPHONIUM SURVIVAL KIT

- soft, clean cloth
- valve oil
- mouthpiece cleaning brush
- slide grease
- pencil
- band music
- method book
- music stand

# BARITONE & EUPHONIUM SURVIVAL KIT

The numbers indicate which valves should be pressed down.

0 = No valves are pressed down.

F#	Gb	G	G#	Ab	A
1 2 3		1 3	2 3		1 2

A#	Bb	B	Cb	B#	C	C#	Db
1		2		0		1 2 3	

D	D#	Eb	E	Fb	E#	F
1 3		2 3		1 2		1

F#	Gb	G	G#	Ab	A	
2		0		2 3		1 2

A#	Bb	B	Cb	B#	C	C#	Db	D
1		2		0		1 2		1

D#	Eb	E	Fb	E#	F	F#	Gb	G
2		0		1		2		0

# BOOT SCOOTIN' BARN DANCE

Bariitone

Ron Cowherd  
Traditional American Folk

1 Allegro

2 3 4 Tap foot 5 6 7

8 9 10 11 12 13 14

15 16 17 18 19 20 21 Tap foot

22 Clap hands 23-24 2 25 26 27 28 29

30 31 32 33 34 35 36

37 38 39 40 41 42 43-44 2

45 46 47 48 49 50 51

52 53 54 55 56 57 58 59 60

61 62 63-64 2 65 Clap hands 66 Slap knee 67 Tap foot 68 Hey!

*f* *mf* *f*

A significant part of a country's heritage and culture is found in its folk music. Using the language of the common folk, folk songs describe the lives and times of its people. This piece uses the folk song, **Ol' Joe Clark**. Joe Clark was a veteran from the war of 1812 who lived in the Appalachian Mountains. The numerous verses were made up from incidents in his life and expanded as time passed to include over 90 different verses.

# BOOT SCOOTIN' BARN DANCE

Bariitone

Ron Cowherd  
Traditional American Folk

1 **Allegro** 2 3 4 Tap foot 5 6 7

8 9 10 11 12 13 14

15 16 17 18 19 20 21 Tap foot

22 Clap hands 23-24 2 25 26 27 28 29

30 31 32 33 34 35 36

37 38 39 40 41 42 43-44 2

45 46 47 48 49 50 51

52 53 54 55 56 57 58 59 60

61 62 63-64 2 65 Clap hands 66 Slap knee 67 Tap foot 68 Hey!

*f* *mf* *f* *mf*

A significant part of a country's heritage and culture is found in its folk music. Using the language of the common folk, folk songs describe the lives and times of its people. This piece uses the folk song, **Ol' Joe Clark**. Joe Clark was a veteran from the war of 1812 who lived in the Appalachian Mountains. The numerous verses were made up from incidents in his life and expanded as time passed to include over 90 different verses.

# BOOT SCOOTIN' BARN DANCE

Bariitone

Ron Cowherd  
Traditional American Folk

1 Allegro

2 3 4 Tap foot 5

6 7

8

9 10 11 12 13 14

15 16 17 18 19 20 21 Tap foot

22 Clap hands 23-24 2 25 26 27 28 29

30 31 32 33 34 35 36

37 38 39 40 41 42 43-44 2

45 46 47 48 49 50 51

52 53 54 55 56 57 58 59 60

61 62 63-64 2 65 Clap hands 66 Slap knee 67 Tap foot 68 Hey!

*f* *mf*

A significant part of a country's heritage and culture is found in its folk music. Using the language of the common folk, folk songs describe the lives and times of its people. This piece uses the folk song, **Ol' Joe Clark**. Joe Clark was a veteran from the war of 1812 who lived in the Appalachian Mountains. The numerous verses were made up from incidents in his life and expanded as time passed to include over 90 different verses.